

# HSX Steam Generator

## Installation and Operating Manual

(This manual also applies to the FSX & PSX models.)

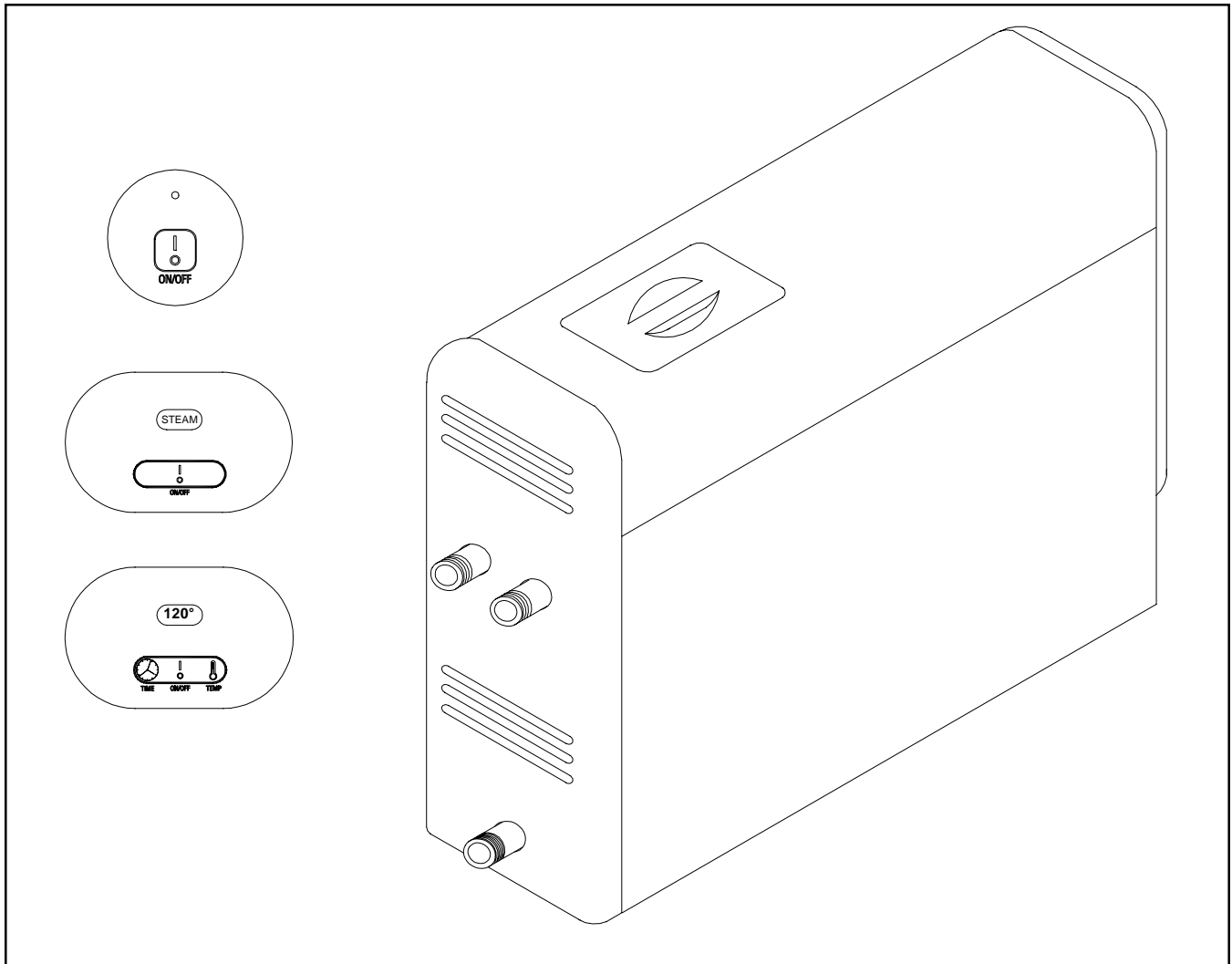

# IMPORTANT SAFETY INFORMATION

## READ ALL INSTALLATION INSTRUCTIONS

Prolonged periods of use of the steamer are not recommend. Prolonged use of the steam system can raise excessively the internal human body temperature and impair the body's ability to regulate its internal temperature (hyperthermia). Consult your physician about your safety and comfort before using the steam system. Limit your use of steam to 10–15 minutes until you're certain of your body's reaction. A cooling shower spray can be used simultaneously with the steam to assist in regulating your body temperature.

Alcohol and certain drugs or medications, such as tranquilizers, affect a person's ability to withstand high temperatures and may produce dangerous side effects. Don't use alcohol or drugs when using steam.

The elderly, the infirm, and children should not use the steamer unattended. Pregnant women and people with heart conditions should consult their physicians before using the steamer.

The wet surfaces of steam enclosures can be slippery. Use care when entering and exiting.

Do not place or use electrically connected devices, such as television, radio, or stereo speakers, lights, hair dryers, or telephones, within 1.5 m (5 feet) of a steam enclosure, shower, or bath.

Read and follow manufacturer's safety information with all optional equipment.

The steam head is hot. Do not touch the steam head or the steam within one foot distance of the head or surfaces surrounding the steam head.

Do not block or obstruct the steam head in any manner.

Do not store or use flammable liquids near the steam generator.

## Save These Instructions for Future Use.

**Post "Steambath Instruction" label outside steambath for Safety Warnings.**

## Inspection and Shipping Claim

Check for shipping damage upon receipt of the product. Saunatec is not responsible for damage to the product sustained during shipping. If damage is evident before unpacking, see instructions regarding shipping claims on the outside of the carton and immediately file a claim with the carrier.

Once the product has been removed from the carton and before it is permanently installed, check the parts completely for damage resulting from shipping or handling. All products are factory tested for proper operation and watertight connections prior to shipping. If problems are detected, immediately notify Saunatec at 1-888-780-4427 for Warranty Service.

NOTE: Damage or defects which could have been discovered and repaired prior to installation and which are claimed after final installation of the product are excluded from our warranty.

### *Owner's Record*

Date Purchased \_\_\_\_\_

Purchased From \_\_\_\_\_

Installed By \_\_\_\_\_

Serial Number \_\_\_\_\_ Model # \_\_\_\_\_

(The serial number is located on the end of the steam generator)

# Contents

## Installation of Steam Generator

Specifications	1
How to Select Generator Size and Electrical Requirements	2
Locating the Steam Generator	3
Room Construction and Ventilation	3
Plumbing Instructions and Cautionary Notes on Installation	4
Plumbing Diagram	5
Steam Head Installation for Various Wall Surfaces	6, 7
Automatic Drain Valve Installation (Optional)	8

## Steam Controls—Operating Instructions and Installation Methods

Steam Control Options	9
Steam Control by 30 Minute “ON/OFF” Control	10
Rough-In and Installation of Temperature Controls (SX30 & SX60)	11, 12

## Operating Instructions

Steam Control by 30 Minute Temperature Control (SX30)	13
Steam Control by Digital Time and Temperature Control (SX60)	14
Service	15
Troubleshooting	16, 17
Wiring Diagram	18
Warranty	19, 20

## GENERAL DESCRIPTION

HSX steam generators are designed for compact size and easy installation and provide full, high volume steam for luxurious steam bathing. The accessories and control options have been designed for easy plug-in installation and function with all sizes of generators. **For residential use only.**

33" FOR PLUMBING CLEARANCE WITH AUTOMATIC DRAIN VALVE.  
(27" WITH MANUAL VALVE IF VALVE IS INSTALLED HORIZONTALLY. 25" WITH MANUAL VALVE IF ELBOW IS ADDED TO INSTALL VALVE VERTICALLY WITH DRAIN LINE.)

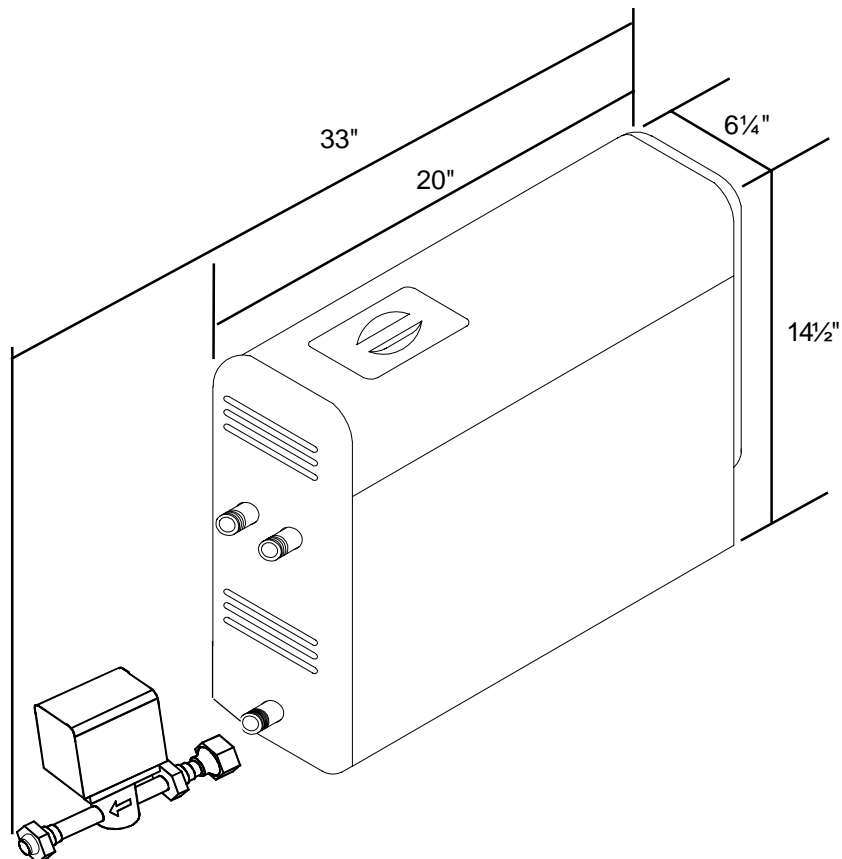

# INSTALLATION

## Specifications and Sizing of the Steam Generator for the Room

MODEL	UL TYPE	WATTS	VOLTS	PHASE	AMPS	WIRES	SIZE	MAX. SIZE OF ENCLOSURE (CUBIC FEET)
HSX-45	1721-45-01D	4500	240	1	18.8	2+GND	10	100
			208	3	12.5	3+GND	12	
			208	1	21.6	2+GND	10	
HSX-65	1721-65-01D	6500	240	1	27.1	2+GND	8	200
			208	3	18.0	3+GND	10	
			208	1	31.3	2+GND	8	
HSX-80	1721-80-01D	8000	240	1	33.3	2+GND	6	300
			208	3	22.2	3+GND	10	
			208	1	38.5	2+GND	6	
HSX-100	1721-100-01D	10000	240	1	41.7	2+GND	6	400
			208	3	27.8	3+GND	8	
			208	1	48.1	2+GND	4	
HSX-120	1721-120-01D	Note: 1	240	1	33.3 / 16.7	4+GND	8	500
		12000	208	3	33.3	3+GND	6	
			Note: 1	208	1	38.5 / 19.2	4+GND	
HSX-140	1721-140-01D	Note: 1	240	1	38.9 / 19.4	4+GND	6	600
		14000	208	3	38.9	3+GND	6	
			Note: 1	208	1	44.9 / 22.4	4+GND	

DIAGRAM 1

NOTE 1 : THESE GENERATORS REQUIRE TWO SEPERATE CIRCUITS FROM BREAKER BOX.

### How to Select Generator Size \*

- Step 1. Determine cubic footage of steam enclosure: multiply LENGTH inches x WIDTH inches x HEIGHT inches to find cubic inches. Divide cubic inches by 1728 to determine cubic feet.
- Step 2. Find steam enclosure size within the ranges shown on the chart for the supply voltage (240 VAC or 208 VAC).
- Step 3. Consider material and climate: If the steam enclosure is constructed of tile or marble or if the steam enclosure is against poorly insulated outside walls in a cold climate, select the next higher or highest kW size of steam generator available. Natural stone such as marble may reduce the cubic capacity by as much as 50%.

### Electrical Requirements

All generators operate at 208 or 220 to 240 VAC at 50 or 60 Hz. Circuits for generators 10Kw or less are to be single phase 3-wire (two conductor) or Three phase 4-wire, (three conductor) at line voltage, and one ground conductor must be provided. Refer to (diagram 1) for the specific wiring requirements. Generators of 12Kw and 14Kw require two separate circuits.

**Caution: Without proper grounding, a system malfunction may cause fatal shock.**

\* See steam generator construction & sizing guide for more detailed calculations on different surface materials.

# INSTALLATION

## Locating the Steam Generator

The steam generator must be installed upright and level. The steam generator must be located within a 25 foot maximum steam line run to the steam head **AND** within the 25 foot control wire length to any controls. It may stand attached to a horizontal base or to a wall. For wall mounting, use mounting brackets as shown at right. The screws must be set directly into studs or equivalent supports. Drill pilot holes on 16" centers and install one #10 1-1/2" screws for each bracket. Carefully hang the generator on the two installed brackets. Secure the generator to the brackets by attaching four #8 x 1" blunt end screws through the bracket into the holes in the bottom of the generator.

Install the steam generator indoors only and in a dry location that will not be subject to freezing. If exposure to freezing can not be avoided (e.g., seasonal-use homes), the optional automatic drain valve **must** be installed. Turn off the power and water supply to the unit if it will not be used for an extended period of time.

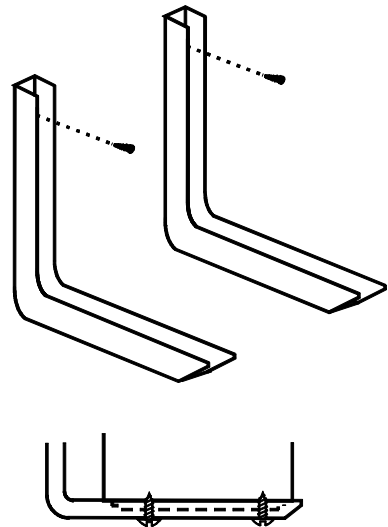

## Room Construction and Ventilation: Important

The room in which the steam generator is to be located must be constructed of materials that can withstand excessive amounts of moisture and condensation. Large amounts of steam can be released into the room when the enclosure door is opened. Providing natural or forced ventilation of the room will help maintain comfort and minimize moisture damage to the building. Saunatec is not responsible for damage resulting from excessive moisture. Consult an architect or engineer for aid in designing your room structure.

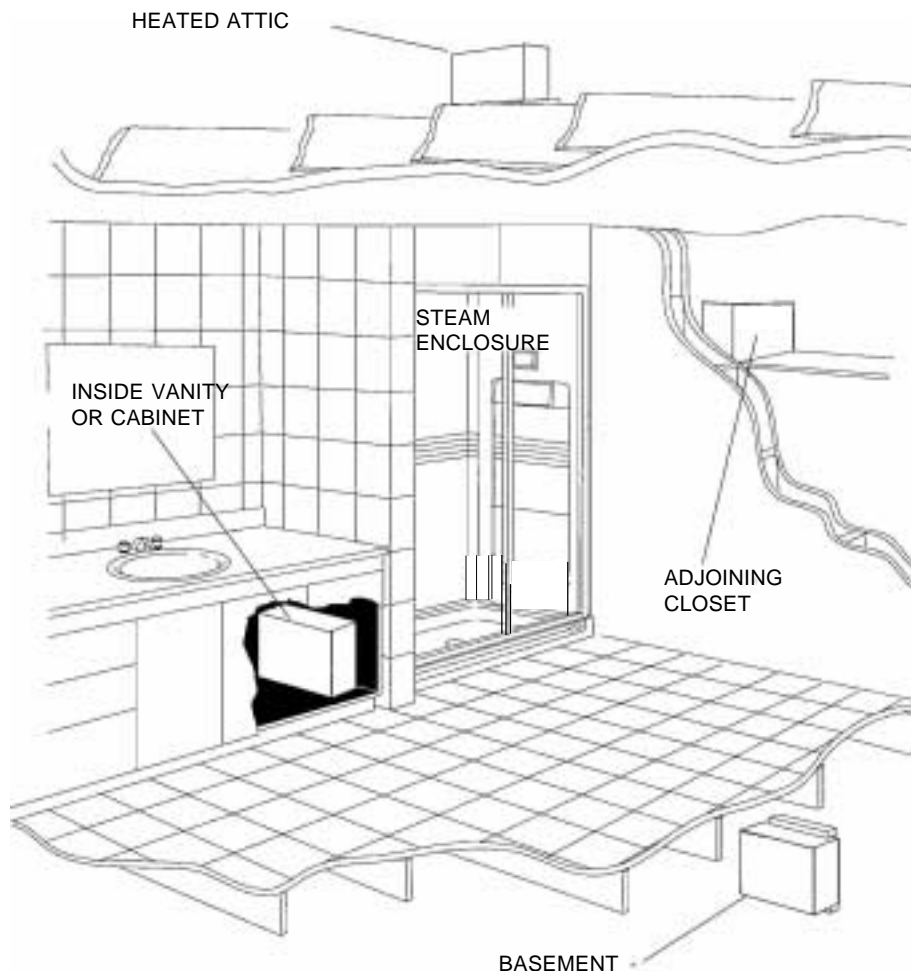

# INSTALLATION

## Plumbing Instructions and Cautionary Notes on Installation

Minerals in the water or poor water quality can shorten the life of the steam generator or cause erratic operation if the tank is not drained regularly. Drain the tank frequently. Saunatec strongly recommends purchasing and installing the **optional Automatic Drain Valve**. See the important note below. The tank will be drained automatically after each use after the water temperature lowers. Water filters and other conditioners are strongly recommended if the water is of poor quality. Contact service for more information.

Guard against possible contact with hot steam pipes and other plumbing.

Maximum run of the steam pipe is 25 feet. The steam pipe should be insulated. This will reduce condensation in the steam line and will increase efficiency. Use only copper and brass pipe and fittings, 1/2 inch minimum.

Install a **water supply shutoff valve** where it is easily accessible.

The water supply pipe should be attached to cold supply. Do not use a saddle or piercing type connection for the steam unit water supply.

Apply thread compound sparingly to fitting threads such that excess compound does not dislodge and restrict the copper pipes or filter screen. Flush lines before making connections to the generator.

When tightening or loosening fittings, **always use a backup wrench to hold the adjacent fitting**.

**Caution:** Do not install any valves or create restrictions in the steam line. **Do not construct any dips or valleys in the steam line** as condensation will accumulate in these and block the pipe with water. Pitch the steam line such that condensation will run to the steam generator (preferable) or to the steam head.

### Important Note About Tank Drain Selection:

Saunatec strongly recommends purchasing and installing the optional Automatic Drain Valve for the steam generator. This drain valve prevents standing water from remaining in the tank between uses.

The Automatic Drain Valve **must** be installed where the steam generator may be exposed to freezing temperatures, e.g., in seasonal-use homes. (Water supply lines and water solenoid valve must not be allowed to freeze.) This option prevents standing water from remaining in the tank. The tank will be automatically drained through this valve when the water has cooled.

Read all warranty provisions before selecting a manual drain valve or the automatic drain down option.

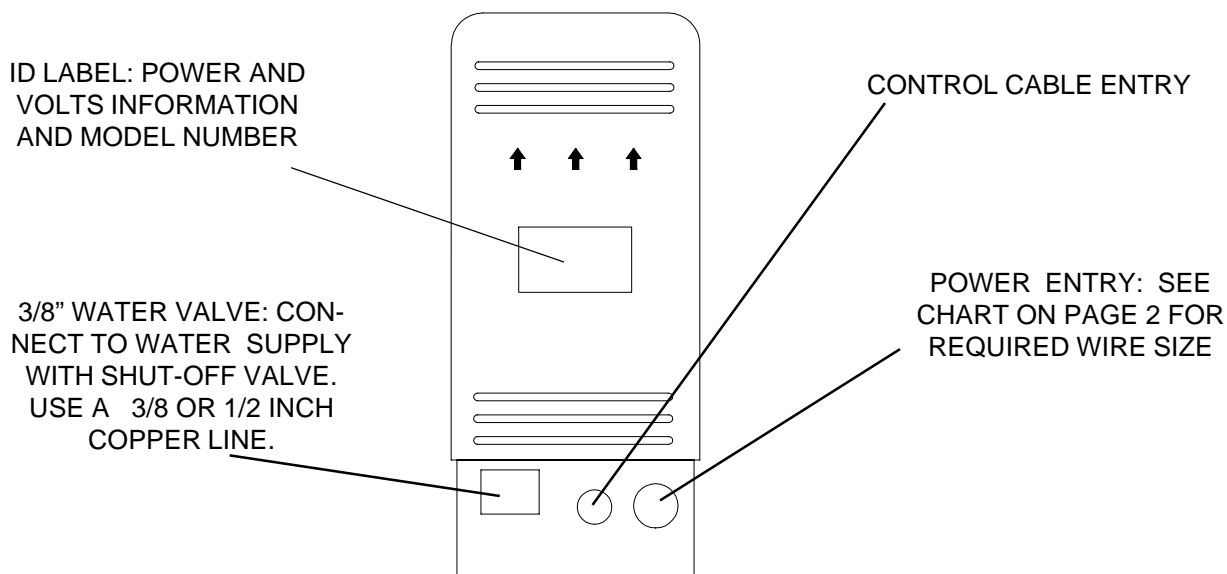

# INSTALLATION

## Plumbing Diagram

PRESSURE RELIEF VALVE (PROVIDED WITH STEAM GENERATOR)

REDUCTION FROM 3/4" TO 1/2" PERMITTED

PRESSURE RELIEF VALVE DRAIN LINE DRAIN LOCATION AND METHOD AS REQUIRED BY LOCAL CODES. (TO BE 1/2 INCH MINIMUM SIZE COPPER)

TO INSTALL STEAM HEAD SEE PAGE 6 FOR STEAM HEAD PLUMBING AND INSTALLATION FOR VARIOUS WALL SURFACES.

STEAM PIPE 1/2 INCH (MINIMUM SIZE) COPPER. 25 FOOT TOTAL MAXIMUM RUN. DO **NOT** PLACE **ANY** VALVES OR DIPS IN THIS LINE. PIPE INSULATION RECOMMENDED

\*SHOWN WITH OPTIONAL AUTOMATIC DRAIN VALVE (SEE PAGE 8)

1/2" TANK DRAIN LINE. INSTALL SITE DRAIN OR OTHER DRAINAGE METHOD AS REQUIRED BY LOCAL CODES (WITH AUTOMATIC DRAIN OPTION, WATER DISCHARGED IS LESS THAN 140°F).

NOTE: ALL COPPER PIPE SIZES ARE TO BE INDUSTRY **NOMINAL SIZES**. PLUMBING AND FITTINGS ARE NOT PROVIDED UNLESS NOTED OTHERWISE.

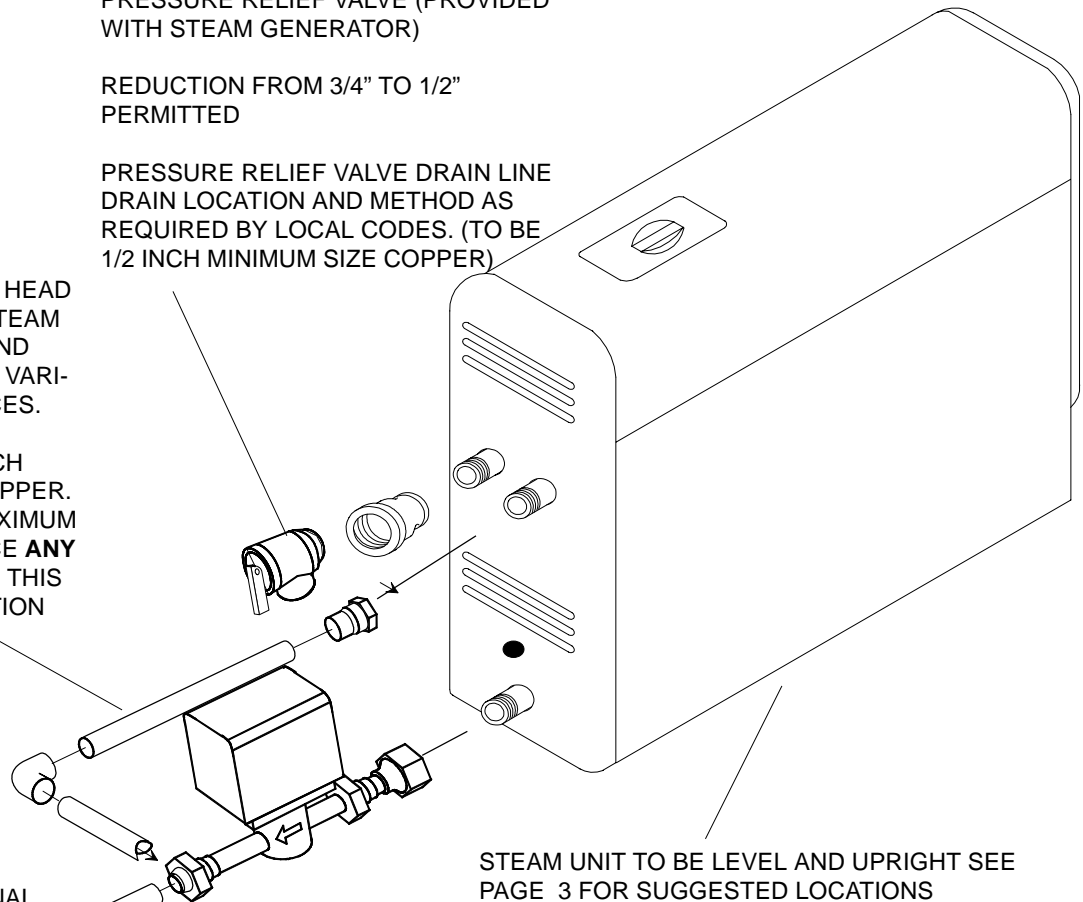

STEAM UNIT TO BE LEVEL AND UPRIGHT SEE PAGE 3 FOR SUGGESTED LOCATIONS

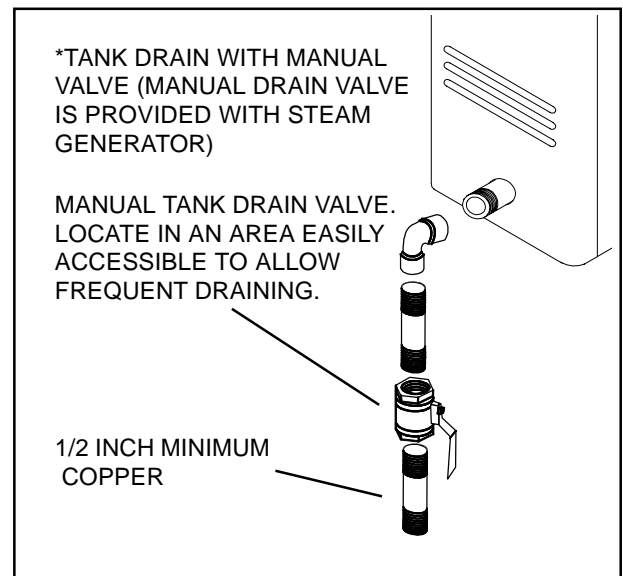

\*TANK DRAIN WITH MANUAL VALVE (MANUAL DRAIN VALVE IS PROVIDED WITH STEAM GENERATOR)

MANUAL TANK DRAIN VALVE. LOCATE IN AN AREA EASILY ACCESSIBLE TO ALLOW FREQUENT DRAINING.

1/2 INCH MINIMUM COPPER

# INSTALLATION

## Steam Head Installation for Various Wall Surfaces

The steam head is to be installed at 17 inches minimum height above the floor or shower base.

The steam head is to be installed at 6 inches minimum above a bath rim.

**Caution:** Consult the manufacturer of the enclosure, shower, or bath unit to verify the suitability of the material for use with steam.

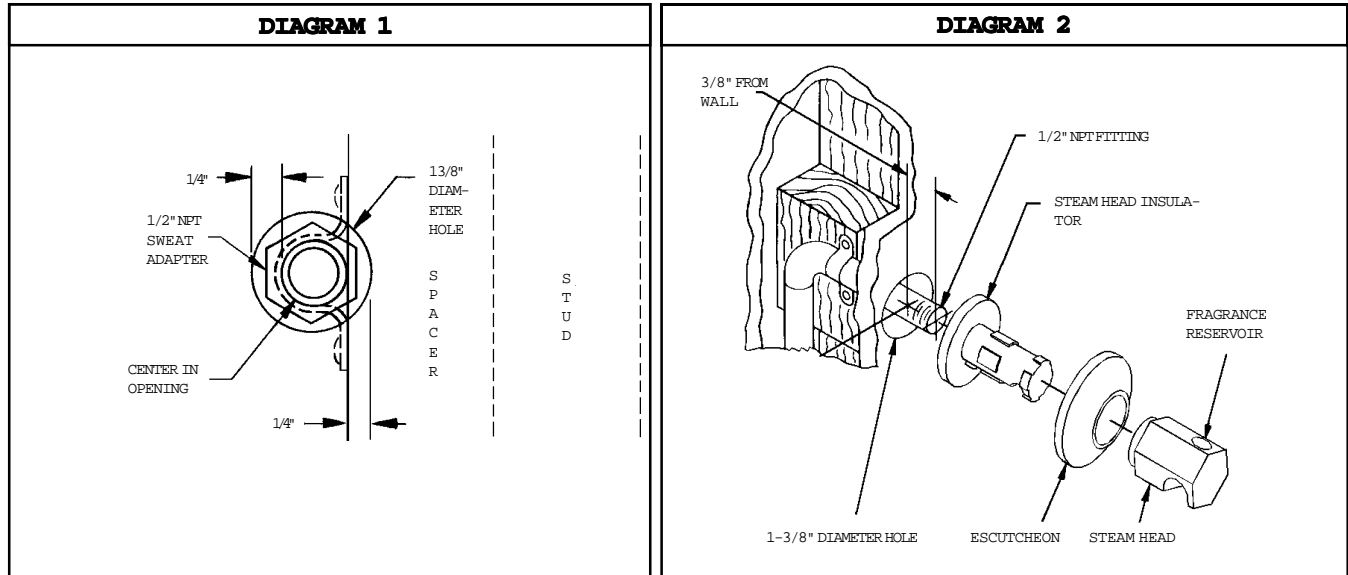

## 10 kW and Higher Steam Generator with Two Steam Heads

Two steam heads may be installed with the Model HSX100 - HSX140 Steam Generator, if desired. This will reduce the sound level of the exiting steam and will provide more even steam distribution and less heat concentration in larger steam enclosures.

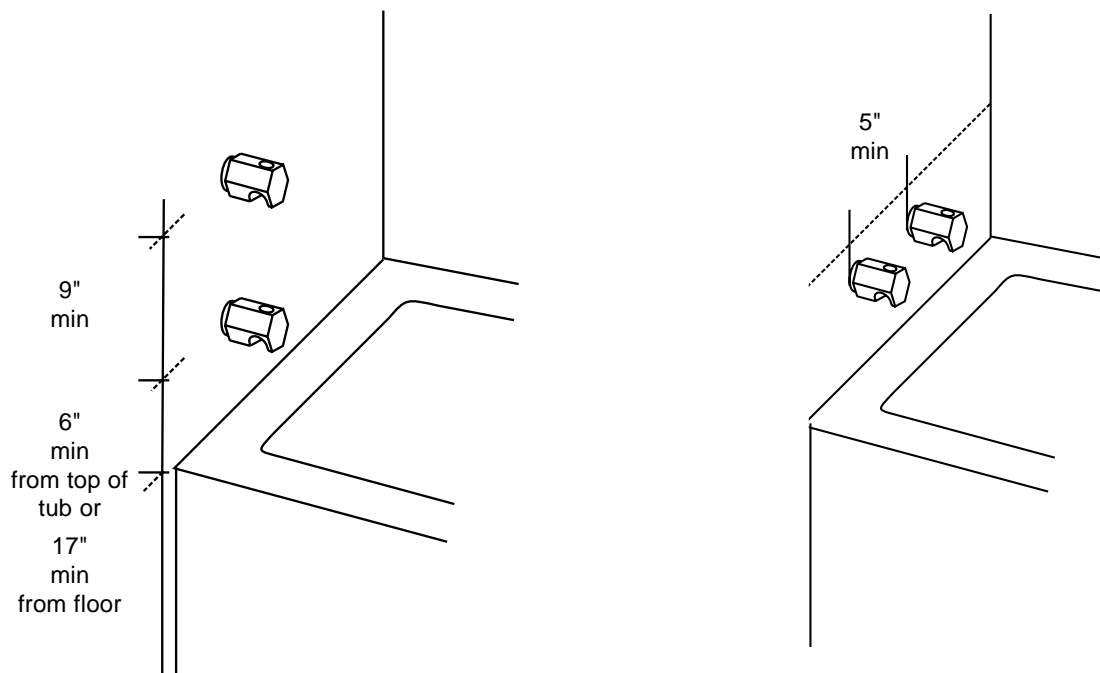

POSITIONING TWO STEAM HEADS WITH MODEL HSX100 - 140 STEAM GENERATORS

# INSTALLATION

## Clearance for proper installation of generator

Allow clearance around the generator for servicing. Minimum clearances are shown below. Service access may be to either side. Minimum volume of installation area is 10 cubic feet.

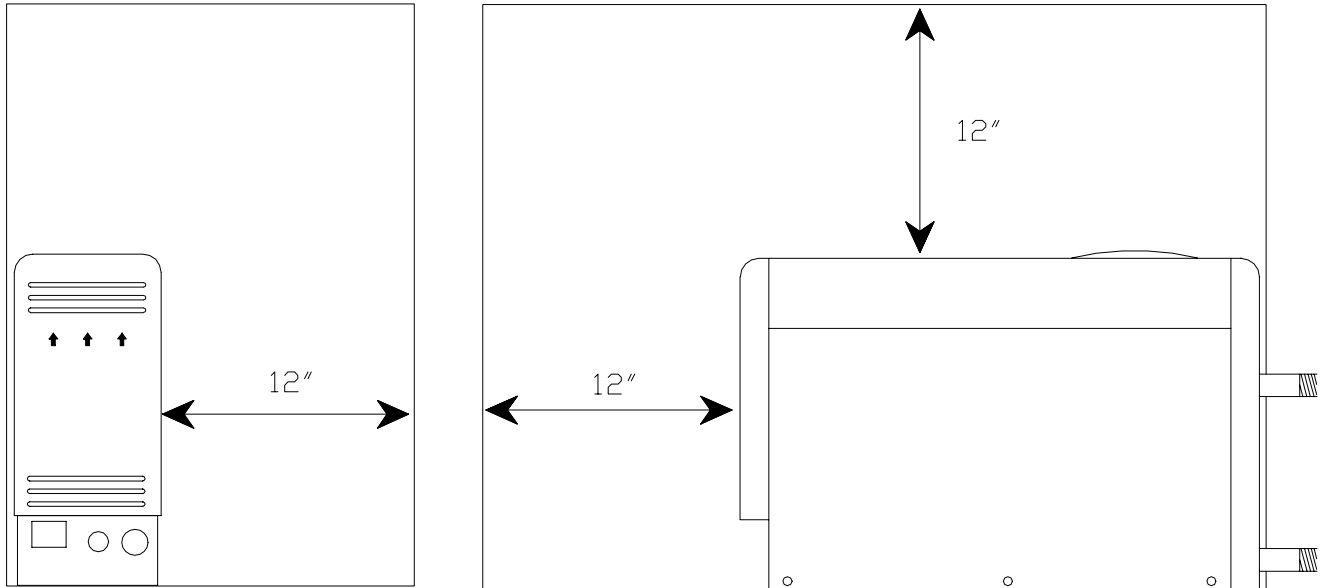

# INSTALLATION

## Automatic Drain Valve Installation (Optional)

### Important Note About Tank Drain Selection:

Saunatec strongly recommends purchasing and installing the optional Automatic Drain Valve for the steam generator. This valve prevents standing water from remaining in the tank between uses.

This valve **must** be installed where the steam generator may be exposed to freezing temperatures, e.g., in seasonal-use homes. This valve automatically drains the tank when the water has cooled.

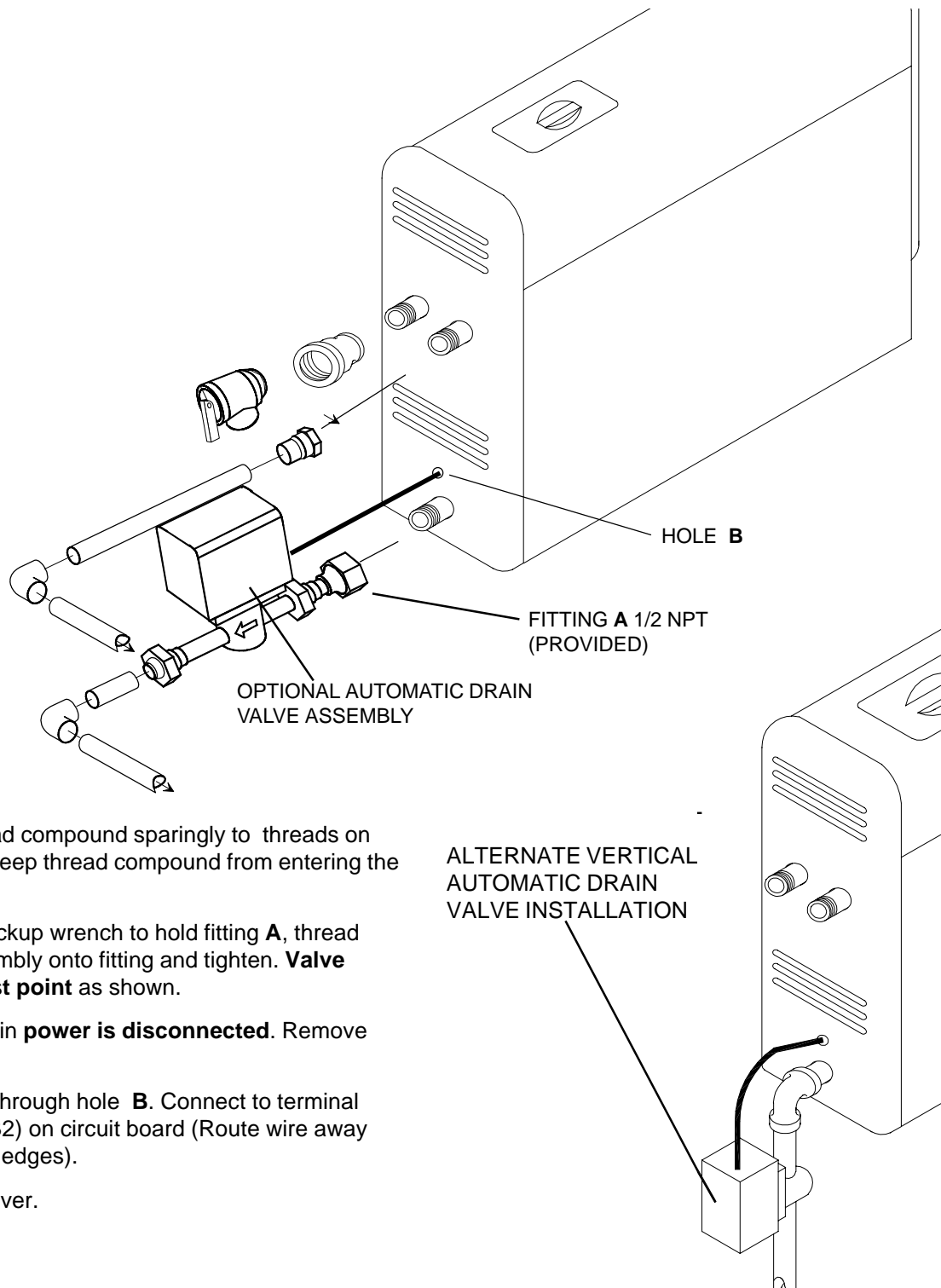

1. Apply thread compound sparingly to threads on fitting **A**. (Keep thread compound from entering the valve.)
2. Using a backup wrench to hold fitting **A**, thread valve assembly onto fitting and tighten. **Valve outlet must point** as shown.
3. Make certain **power is disconnected**. Remove top cover.
4. Feed wire through hole **B**. Connect to terminal block 2 (TB2) on circuit board (Route wire away from sharp edges).
5. Replace cover.

# INSTALLATION

## Steam Controls—Available Options and Installation Methods

Various control packages are available for use with the steam generator. The following instructions (pages 10 - 14) describe the different installations. Select one of the following control options:

**NOTE:** To change controls, always shut off power to steam generator.

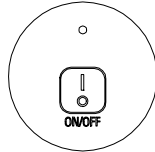

A. ON/OFF 30 minute control.

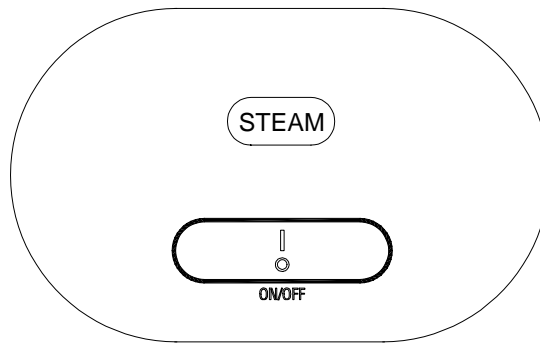

B. 30 minute temperature control.  
(SX30)

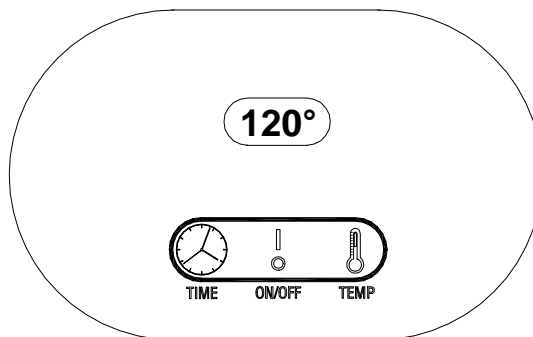

C. Digital time and temperature control.  
(SX60)

# INSTALLATION

## A. STEAM CONTROL BY 30 MINUTE LOW VOLTAGE "ON/OFF" CONTROL.

### 1. Control cable rough-in:

The low voltage control can be mounted **up to 75 feet** from the generator either inside or outside the steam room. (25' cable provided) See #4 for Optional Secondary Generator Control. String (3) 18 to 22 AWG solid wires from the control location through 1/2" holes in the wall studs or ceiling joists to the generator.

Note: 1) Do not staple through or damage wires,  
2) Label or color code wires for proper TB1 to on/off control orientation. See diagram.

### 2. Control cable at the generator

Route control wires through the generator CONTROL WIRING ENTRY and appropriate strain relief. Connect 3 wires to terminal block TB-1 on the printed circuit assembly, as shown in diagram.

### 3. Install on/off generator control

The low voltage control can be mounted directly to a finished wall either inside or outside the steam room. Using a 1-3/4" hole saw, drill a hole in the finished wall where the control is to be mounted (the control wires should already be roughed-in to this location). Locate the control wires, pull them out through the 1-3/4" hole and plug the 3 wires into the connector on the back of the control housing, as shown in diagram. Run a bead of 100% silicone caulk around the perimeter on the back of the control housing. See diagram. Insert the control into the wall cavity.

### 4. Optional second on/off generator control

As an option, a second control can be installed with the generator to provide ON/OFF control both inside and outside the steam room. The second control should be installed as described in paragraphs 1 & 3, with the second control wire plugged into the same connector TB1 connector as the first control on the PCA.

To prepare steam generator:

1. Make certain that **power is disconnected**. Remove cover.
2. Remove and discard plug from hole **A**.
3. Feed wire through hole **A** and connect to **TB1** on the circuit board.
4. Locate strain relief bushing 1" from stripped end of cable jacket with the two connectors. Snap strain relief bushing **B** into hole **A**.
5. Replace cover.

THIS LOW VOLTAGE CONTROL CAN BE LOCATED **INSIDE OR OUTSIDE** THE STEAM ENCLOSURE

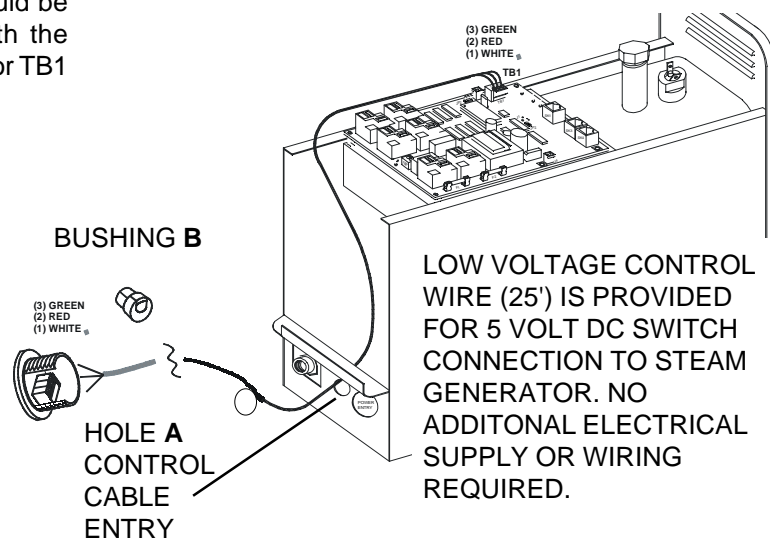
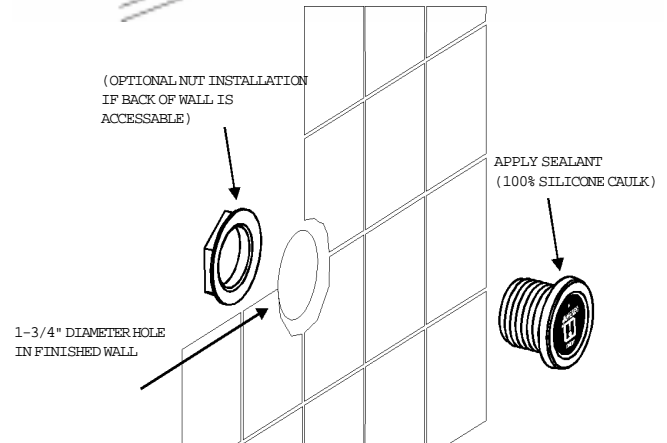
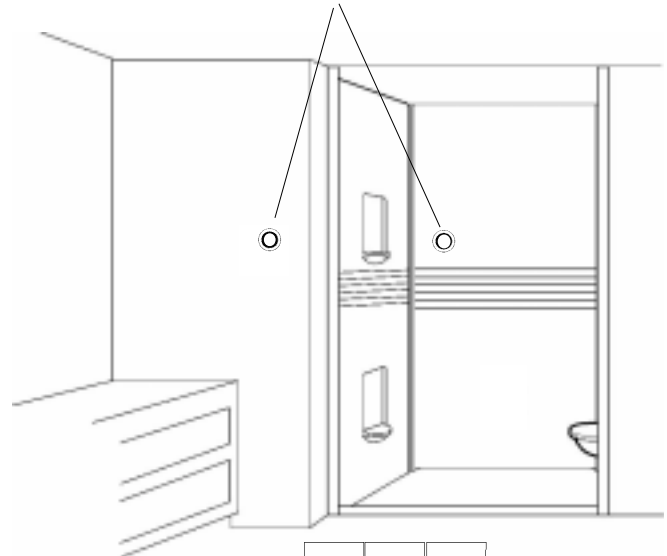

# INSTALLATION

## GENERAL INSTRUCTIONS FOR TEMPERATURE CONTROL MODELS (SX30 & SX60)

### 1. Control Cable Rough-in

The low voltage control can be mounted **up to 25 feet** from the generator either inside or outside the steam room, also see #6 optional secondary digital generator control. String the 25' cable from the control location through 1/2" holes in the wall studs or ceiling joists to the generator. Note: Do not staple through or damage cable. Use factory supplied cables only. Optional for tile rooms, a 1 gang rough-in box may be installed at the desired control mounting location. A mounting plate with proper 2" diameter hole is included with the control kit. Tile up to the 2" hole in the mounting plate.

### 2. Temperature Sensor Rough-in

It is recommended that the sensor be mounted in the steam room 6" from the ceiling, but not directly over the steam dispersion head or more than 7 feet above the floor. String the sensor cable from the sensor location through 1/2" holes in the wall studs or ceiling joists to the generator location. Leave 12" of slack at the sensor location. Note: Do not staple through or damage cable. Use factory supplied cables only.

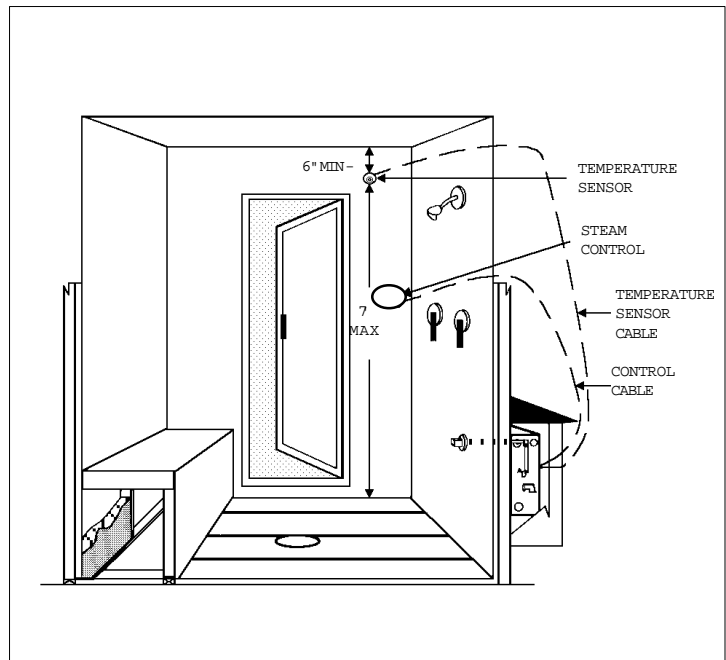

### 3. Electrical Rough-in

Size wire for the generator as indicated by the Electrical Information Chart on page 2. Use correct size and type to meet electrical codes. Leave 4 feet of slack wire at generator location for finish hookup. Connect the generator to a dedicated circuit breaker. A GFI device is not required by UL. One may be installed if required by local codes or the owner. A GFI device will tend to nuisance trip due to heater element aging.

### 4. Electrical finish

Materials (locally available):

- 3/4" Strain relief for supply wire.

- Route the copper supply wire with appropriate strain relief through the hole marked POWER ENTRY.
- Connect the supply wires to the terminal block marked L1 and L2.
- Connect the ground to the ground lug.

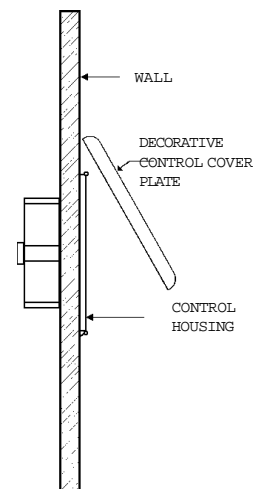
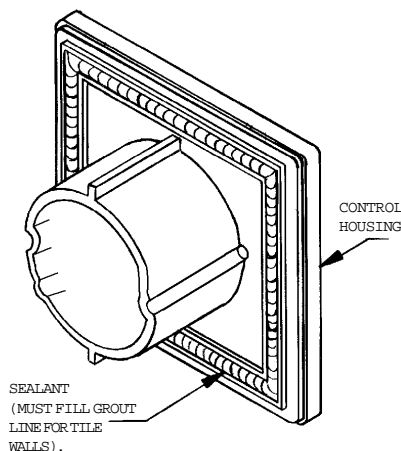
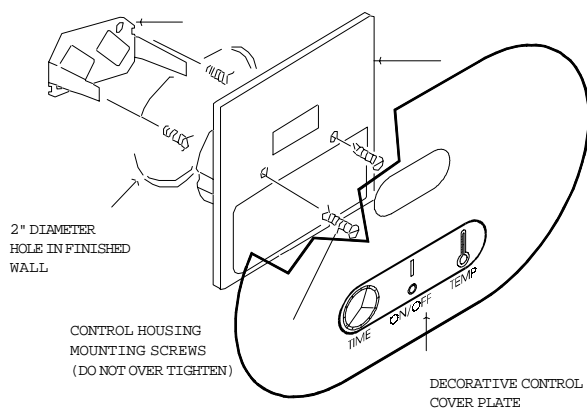

# INSTALLATION

## 5. INSTALL GENERATOR CONTROL

The low voltage control can be mounted directly to a finished wall either inside or outside the steam room. Using a 2" hole saw, drill a hole in the finished wall where the control is to be mounted (the control cable should already be roughed-in to this location). Locate the control cable, pull it out through the 2" hole and plug it into the connector on the back of the control housing. With the decorative cover removed, screw the two 3" control housing mounting screws 1/4" into the mounting bracket. See diagram. Run a bead of 100% silicon caulk in-between the 2 ridges around the perimeter on the back of the control housing. See diagram. Insert the mounting bracket into the wall cavity by first pushing with the control housing and then with a hard flat surface on the control housing mounting screws which extend out through the control face. Once the mounting bracket has been inserted into the finished wall, center the control and tighten the mounting screws to draw the control housing securely against the finished wall. Do not over tighten the mounting screws. Install the decorative cover plate by sliding the top of the cover plate over the tab on the top of the control housing and pushing on the bottom of the cover plate to complete the snap fit. See diagram.

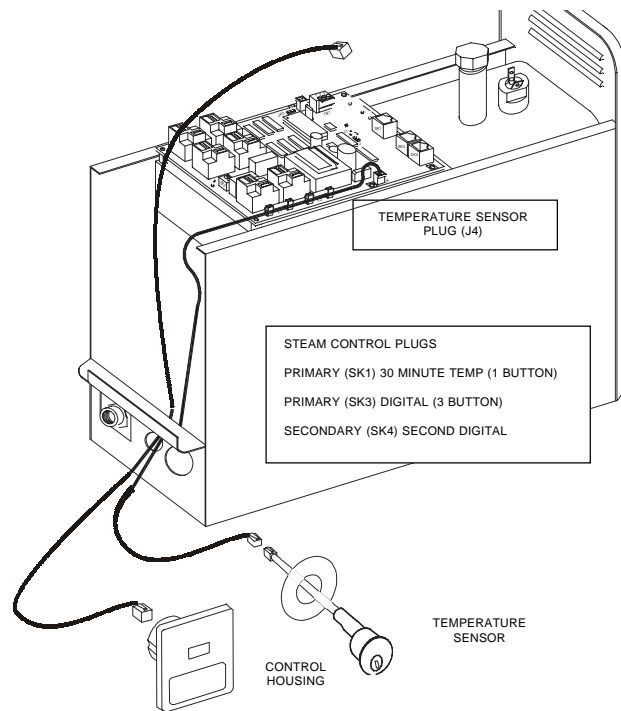

Route the generator end of the control cable through the generator hole marked CONTROL WIRING ENTRY using the strain relief provided. Plug the control cable into the connector on the printed circuit board assembly. Insert cable into connector SK1 if a 30 minute temperature control is used or connector SK3 if a digital control is used. See diagram.

## 6. OPTIONAL SECONDARY GENERATOR CONTROL

As an option, a second digital control can be installed with a generator to provide ON/OFF control both inside and outside the steam room. The second control should be installed as described in paragraphs 1 & 5, with the second control cable plugged into connector SK4 for the digital control on the printed circuit board assembly. See diagram.

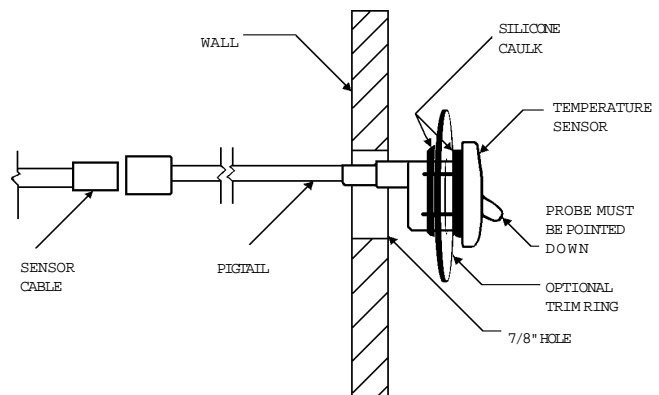

## 7. INSTALL TEMPERATURE SENSOR

The temperature sensor should be mounted 6" below the ceiling, inside the steam room, but not directly over the steam dispersion head or more than 7 feet above the floor. Using a 7/8" hole saw, drill a hole in the finished wall where the sensor is to be mounted (the sensor cable should already be roughed-in to this location). Locate the sensor cable, pull it out through the hole and plug it into the temperature sensor. It is best to tape the sensor and cable connection together to avoid disconnection inside the wall. Apply silicon caulk as shown in diagram and insert the sensor in the hole. An optional trim ring is included with the sensor. If the 7/8" hole is jagged or is cut too large the trim ring may be used to cover the exposed edges. See diagram. Make sure that the sensor probe is pointing down once installed. Tape the sensor in place while the silicone hardens. Route the generator end of the sensor cable through the generator hole marked CONTROL WIRING ENTRY using the control cable strain relief. Plug the sensor cable into the connector marked J4 on the printed circuit board assembly. See diagram.

# OPERATION

## B. 30 MINUTE TEMPERATURE CONTROL (SX30)

The 30 minute temperature control features a 30 minute press on timer lighting up the word "STEAM" and a thermostatic control preset to reach 120 degrees Fahrenheit. The control can be mounted either inside or outside the steam room. The preset temperature can be adjusted in a range between 100 degrees and 125 degrees Fahrenheit. Once the set temperature is reached the "gentle steam" feature automatically engages cutting steam production back to a single element to provide softer billowing steam during more of the steam bath. If the steam room temperature drops more than 5 degrees, all elements will automatically engage.

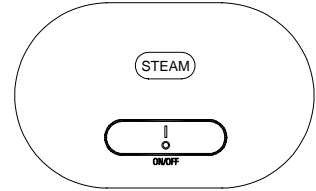

### Operation of Your 30 Minute Temperature Control

1. Be sure the power circuit and water supply to the generator are on.
2. Firmly press the ON/OFF button on the control until the word "STEAM" lights up.
3. The generator should produce steam in 5 to 10 minutes and will turn off automatically in 30 minutes. You may also press the control a second time to turn off the "STEAM" light and shut down the generator.
4. If you wish to change the preset temperature see the instructions below.

### Temperature Adjustment

1. To adjust the set temperature remove the snap-on decorative control cover by lifting from the bottom as shown in diagram.
2. Using a small slotted screw driver turn the adjustment pot in the desired direction. See diagram. One quarter turn equals approximately 7 degrees of temperature change. Caution: Over stressing the adjustment pot can damage the control.
3. Snap the control cover plate back on by sliding the top of the cover plate onto the control housing and pushing on the bottom of the control cover plate. See diagram. The new temperature setting will become effective the next time the steam is turned on.

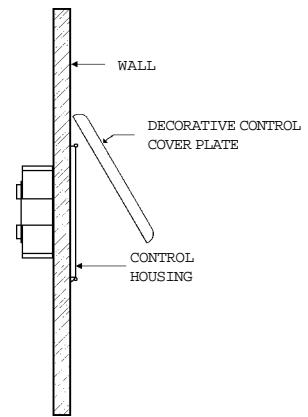
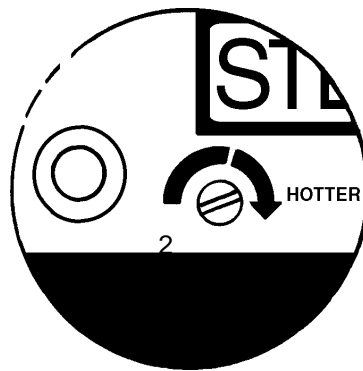
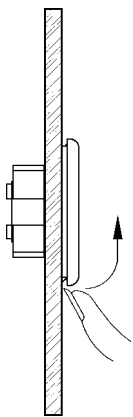

# OPERATION

## C. DIGITAL TIME AND TEMPERATURE CONTROL (SX60)

The digital control features an adjustable 60 minute time and temperature control with digital display. The actual room temperature and time remaining are alternately displayed every 5 seconds. The primary control can be mounted either inside or outside the steam room and an optional secondary control is available to mount in an alternate location. The temperature can be adjusted in a range between 100 degrees and 125 degrees Fahrenheit with an initial default of 120 degrees. Once the set temperature is reached the "gentle steam" feature automatically engages cutting steam production back to a single element to provide softer billowing steam during more of the steam bath. If the steam room temperature drops more than 5 degrees, all elements will automatically engage.

### Operation of Your Digital Time and Temperature Control

1. Be sure the power circuit and water supply to the generator are on.
2. Press the ON/OFF button on the control until the temperature is displayed. To shut down the generator press the ON/OFF button.
3. The generator should produce steam in 5 to 10 minutes and will turn off automatically in 60 minutes or less depending on the set time. The control will alternately display time remaining and the actual temperature at the sensor in your steam room every 5 seconds.
4. To change the time setting press and hold the TIME button on the control. Continuing to hold the button will cause the time to increase in 5 minute increments from the prior setting. At 60 minutes the time setting will scroll backwards to 5 minutes.
5. To change the preset temperature setting press and hold the TEMP button on the control. While continuing to hold the button, the temperature display will increase in 1 degree increments from the prior setting to 125 degrees Fahrenheit. At 125 degrees Fahrenheit the temperature setting will decrease in 1 degree increment to the lowest setting, 100 degrees Fahrenheit.
6. The TIME and TEMP set points are remembered for your next bath unless power to the steam generator is lost.

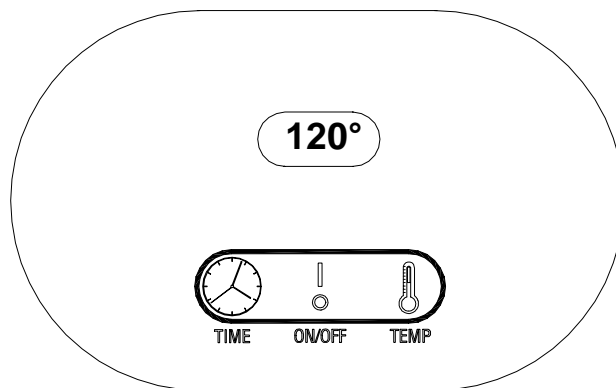

# SERVICE

## Maintenance of Generators

Maintenance of the HSX generator includes flushing the unit periodically and visually inspecting for water leaks. Whenever the generator is opened all wiring should be inspected for any signs of overheating. All electrical connections should be checked for tightness. 12 and 14 Kw units require two separate circuits from breaker box. Make sure both are shut off prior to servicing.

## Repair of Generators

**A. ELEMENT REPLACEMENT:** Disconnect power from the unit. Drain the tank. If the left side element is to be replaced, turn the water supply off and disconnect the water supply from the water solenoid. Remove the electrical end cover. Remove 4 screws and the water solenoid bolts from the electrical entry panel and tilt the panel out of the way. Note the wire connections (wiring diagrams are provided on the side covers). Remove the wires from the element to be replaced. Use a 10mm socket to loosen the nut on the element (do not remove the nut!). Turn the nut so it is even with the end of the element threads then push against the nut to loosen the element seal. Remove the element.

Make sure the element seating area is clean and free of damage or debris then install the new element. Carefully push the new element in until it is fully seated evenly against the tank. While pushing the element into the tank, tighten the element's nut to 65 inch pounds. Inspect the element to ensure it is still against and even with the tank. Reconnect the wiring. Remount the electrical panel and water valve. Reconnect the water supply as needed. Test the unit. Check for leaks at the elements and water valve. Replace the end cover.

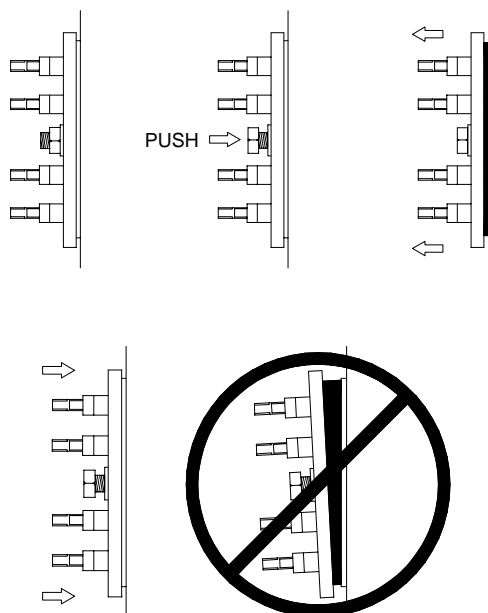

**B. PRINTED CIRCUIT REPLACEMENT:** Disconnect power from the unit. Remove the top and front cover. Note where the blue wire is connected to the double pronged water level probe. Disconnect all wires from the water level probe. Disconnect the two blue wires from the water solenoid and control wires (note locations). Note and tag the position of all wires that plug into the printed circuit assembly mounted relays. Remove all the wires from the relays. When removing these wires pull on the connector and not the wire. 7 screws hold the board in place. Remove all 7 screws. The printed circuit assembly can now be removed. To install the board reverse this procedure. Test the unit. (Remember to reinstall the circuit board ground wire and the fuse cover)

### IMPORTANT

The blue wire connected to "L" on the PCA must be connected to the shortest of the level probes (the one with the bent tab).

**C. WATER SOLENOID REPLACEMENT:** Disconnect power from the unit. Turn the water supply OFF. Disconnect the water supply from the water solenoid valve. Remove the front cover. Remove the two blue wires from the water solenoid valve. Rotate the self-tightening hose clamp so it can be loosened with a pair of pliers. Squeeze the clamp and move it down towards the shelf and off the valve outlet tube. Remove the two 1/4" - 20 hex head bolts and lock washers that attach the valve to the chassis. Pull the valve off the rubber fill hose. To install the valve, reverse this procedure.

**D. LEVEL PROBE REPLACEMENT:** Disconnect power from the unit. Remove the top and front cover. Note where the blue wire is connected to the water level probe. Disconnect all wires from the water level probe. Remove the level probe. Install a new level probe. Tighten until the bottom of the plastic nut is tight against the gasket. Reattach the wires. Test the unit.

### IMPORTANT

The blue wire connected to "L" on the PCA must be connected to the shortest of the level probes (the one with the bent tab).

### IMPORTANT

The level probe may be extremely tight. Damage to the insulation or chassis may result unless the tank is properly blocked or supported during probe removal or installation.

# TROUBLESHOOTING

There are no user serviceable parts in the Generator. All repairs should be performed by a qualified service person. For additional assistance or to locate the factory authorized service person nearest you call the Service Department at 1-888-780-4427. The Trouble Shooting Guide below is meant as a general aid only. Follow ACTION TO BE TAKEN in order until the problem is resolved. Where replacements or repairs are indicated, see the appropriate paragraph of SERVICE SECTION.

SYMPTOMS	PROBABLE CAUSES	ACTION TO BE TAKEN
Control won't turn "ON" (Control light off).	Improper power supplied (no power). Control improperly connected. printed circuit assembly "PCA" is faulty. Control cable is faulty. Control is faulty.	<ol style="list-style-type: none"> <li>1. a. Make sure circuit breaker is "ON".</li> <li style="padding-left: 20px;">b. Using a voltmeter, check the voltage at the power terminal block. Voltage should be 208V / 240V.</li> <li style="padding-left: 20px;">c. Check fuses on the PCA. If fuse(s) are blown, replace with 15/100A Slo-Blo or 1A Fast blow as indicated on PCA. If the fuse blows again - call Service Department.</li> <li>2. Check control(s) installed per Pages 10-12.</li> <li>3. Replace PCA printed circuit assembly - call Service Department.</li> <li>4. Replace control cable - call Service Department.</li> <li>5. Replace the control - call Service Department.</li> </ol>
Control "OFF". (Control light off) Water won't shut off and runs out of the steam head.	Water solenoid valve is stuck open. "PCA" printed circuit assembly is faulty.	<ol style="list-style-type: none"> <li>1. Turn off power to the generator. If the water stops, go to step 3.</li> <li>2. a. Remove the water solenoid valve, disassemble, clean, re-assemble, and check for proper operation.</li> <li style="padding-left: 20px;">b. Replace valve - call Service Department.</li> <li>3. Replace the "PCA" printed circuit assembly - call Service Department.</li> </ol>
Control "ON". (Control light on) Water won't shut off and runs out of the steam head.	"PCA" printed circuit assembly is faulty. Connection between the blue wire and the water level probe is faulty. Unit improperly grounded.	<ol style="list-style-type: none"> <li>1. Check that the blue wire is properly attached to the water level probe.</li> <li>2. Check that the generator is properly grounded.</li> <li>3. Check the green ground wires to the "PCA" printed circuit assembly.</li> <li>4. Replace the "PCA" printed circuit assembly - Service Department.</li> </ol>
Control "ON" (Control light on), Tank drained. Unit won't fill.	No water supplied (turned off?) Plugged water solenoid valve. Water solenoid valve is faulty. "PCA" printed circuit assembly is faulty. Level probe is faulty.	<ol style="list-style-type: none"> <li>1. Check for proper water supply (Supply valve "on"). Check for closed drain valve.</li> <li>2. Check 1a fuse.</li> <li>3. Remove the blue wire from the level probe. If the unit fills, clean or replace the level probe.</li> <li>4. Reconnect the blue wire to the level probe. At the water valve solenoid, slide back the blue connector enough to get the voltmeter probes on the solenoid terminals. Measure the voltage across the solenoid terminals. If it is not 208V / 240V replace the printed circuit assembly. If 208V / 240V is found proceed with steps 4 &amp; 5.</li> <li>5. Remove water solenoid valve; disassemble, clean, reassemble, and check for proper operation.</li> <li>6. Replace the water solenoid valve - call Service Department.</li> </ol>
(Auto Drain Only Installations) Control turned "OFF" tank does not drain after 25 minutes and motorized drain valve stays closed.	"PCA" printed circuit assembly is faulty. Drain valve may be clogged with calcium.	<ol style="list-style-type: none"> <li>1. a. Make sure 25 minutes has elapsed.</li> <li style="padding-left: 20px;">b. Disconnect drain valve wires. If drain valve opens replace "PCA"</li> <li>2. Turn off power - if unit still does not drain, the drain line or the valve may be plugged.</li> <li>3. a. Disassemble drain valve and clean.</li> <li style="padding-left: 20px;">b. Clean tank using delimiting solution</li> </ol>

# TROUBLESHOOTING

SYMPTOMS	PROBABLE CAUSES	ACTION TO BE TAKEN
<p>Control "ON". (Control light on) Unit won't steam.</p> <p>Note: Steam lit steadily or Time/Temp properly displayed on Digital Display</p>	<p>Unit has not filled completely. Heating elements burnt out. Level probe faulty. "PCA" printed circuit assembly is faulty.</p>	<ol style="list-style-type: none"> <li>1. a. Push the control "OFF". b. Open the drain valve allowing tank to drain completely. c. Close the drain valve. d. Push the control "ON". e. Unit will begin filling, listen for a click noise. Within 20 seconds after click noise is heard, the water fill will shut off. This will indicate the tank is full. Go to step 3, if the tank does not fill - See SYMPTOMS: "Unit won't fill up".</li> <li>2. Measure voltage across small terminal block near elements. If 10VAC is present then call Service.</li> <li>3. If the tank filled but the relay click was not heard, temporarily ground the white wire to the level probe. If the click is heard, re-connect the wire. If the click is not heard, replace the "PCA" printed circuit assembly.</li> <li>4. After it has been determined that the tank has filled and the click noise was heard, use a voltmeter to check the voltage between the two wires on each heating element - the voltage should be 208V/240V. If proper voltage is found call the factory for replacement heating elements. If no voltage is found - check wiring diagram - call Service Department.</li> </ol>
<p>Control "ON". Digital Control displays "E001"</p>	<p>Temperature sensor not connected, or cable is open.</p>	<ol style="list-style-type: none"> <li>1. Check that the sensor cable is connected to J4 on the "PCA" printed circuit assembly.</li> <li>2. Check cable for damage.</li> <li>3. Check the cable connection to the temperature sensor.</li> <li>4. Replace sensor and/or cable - call Service Department.</li> </ol>
<p>Control "ON". Digital Control displays "E002"</p>	<p>Temperature sensor or cable shorted.</p>	<ol style="list-style-type: none"> <li>1. Check sensor cable for damage from nail/staple puncture.</li> <li>2. Check sensor cable ends for frayed/exposed wire strands.</li> <li>3. Replace sensor and/or cable - call Service Department.</li> </ol>
<p>Control "ON". Digital Control displays "E003"</p>	<p>Control improperly connected.</p>	<ol style="list-style-type: none"> <li>1. Check that the control cable is properly plugged in at the control and at the generator. Digital Control to primary SK3 connector on the PCA. Turn off power supply, wait one (1) minute then turn back on. Check for proper operation. If "E003" is still displayed turn off power supply, remove control cable and plug into secondary SK4 connector. Turn on power supply and check for proper operation. If "E003" is still displayed turn off power and call Service Department.</li> </ol>
<p>Control "ON". Digital Control displays "&gt;&gt;&gt;"</p>	<p>Steambath temperature over 132°. Sensor/cable faulty.</p>	<ol style="list-style-type: none"> <li>1. If bath is too hot, shut off circuit breaker and call Service Department.</li> <li>2. Treat as "E002" fault above.</li> </ol>
<p>Control "ON". "STEAM" LED light blinking</p>	<p>Control improperly connected. Sensor/cable faulty. Control faulty.</p>	<ol style="list-style-type: none"> <li>1. Check that the control cable is properly plugged in at the control and at the generator. Connect Control to primary SK1 connector on the PCA. Turn off power supply, wait one (1) minute then turn back on. Check for proper operation. If "STEAM" is still "blinking", turn off power supply and call Service Department.</li> <li>2. Check sensor/cable as with Digital "E001" and "E002"</li> <li>3. Replace Control - call Service Department.</li> </ol>
<p>Control won't turn "OFF" (Control light on).</p>	<p>Control is faulty.</p>	<ol style="list-style-type: none"> <li>1. Replace the control - call Service Department.</li> </ol>
<p>Control "OFF" Unit won't shut off.</p>	<p>"PCA" printed circuit assembly is faulty.</p>	<ol style="list-style-type: none"> <li>1. Turn off the power to the generator, replace printed circuit assembly - call Service Department.</li> </ol>
<p>Water continually sputters out of steam head.</p>	<p>Foaming contaminants in the water.</p>	<ol style="list-style-type: none"> <li>1. Flush tank 3 times. See section 8, flushing procedure.</li> <li>2. Call Service Department.</li> </ol>
<p>Unable to adjust Time or Temp setting with Digital Control</p>	<p>Control faulty. "PCA" printed circuit assembly is faulty.</p>	<ol style="list-style-type: none"> <li>1. Replace control - call Service Department.</li> <li>2. Replace PCA - call Service Department.</li> </ol>

# WIRING DIAGRAM

4.5kW/6.0kW/8kW/10kW 208/240VAC STEAM GENERATORS

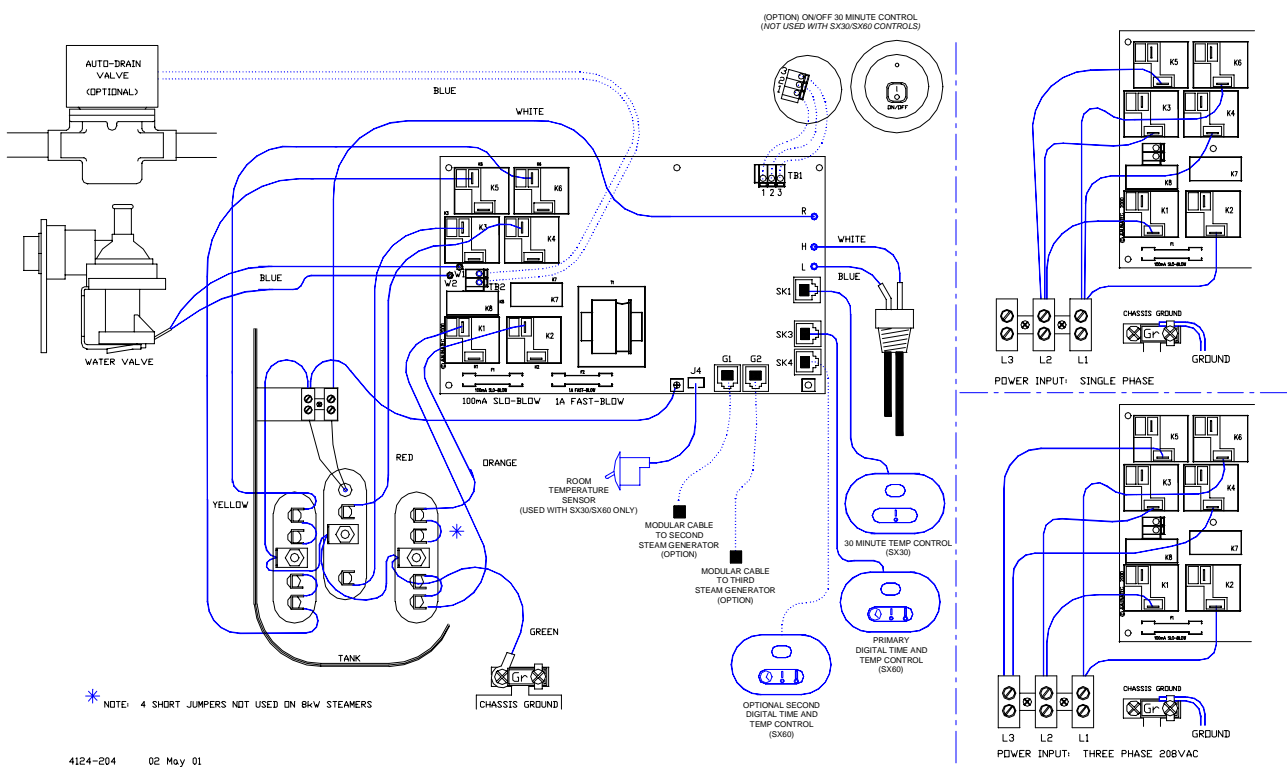

12kW/14kW 208/240VAC STEAM GENERATORS

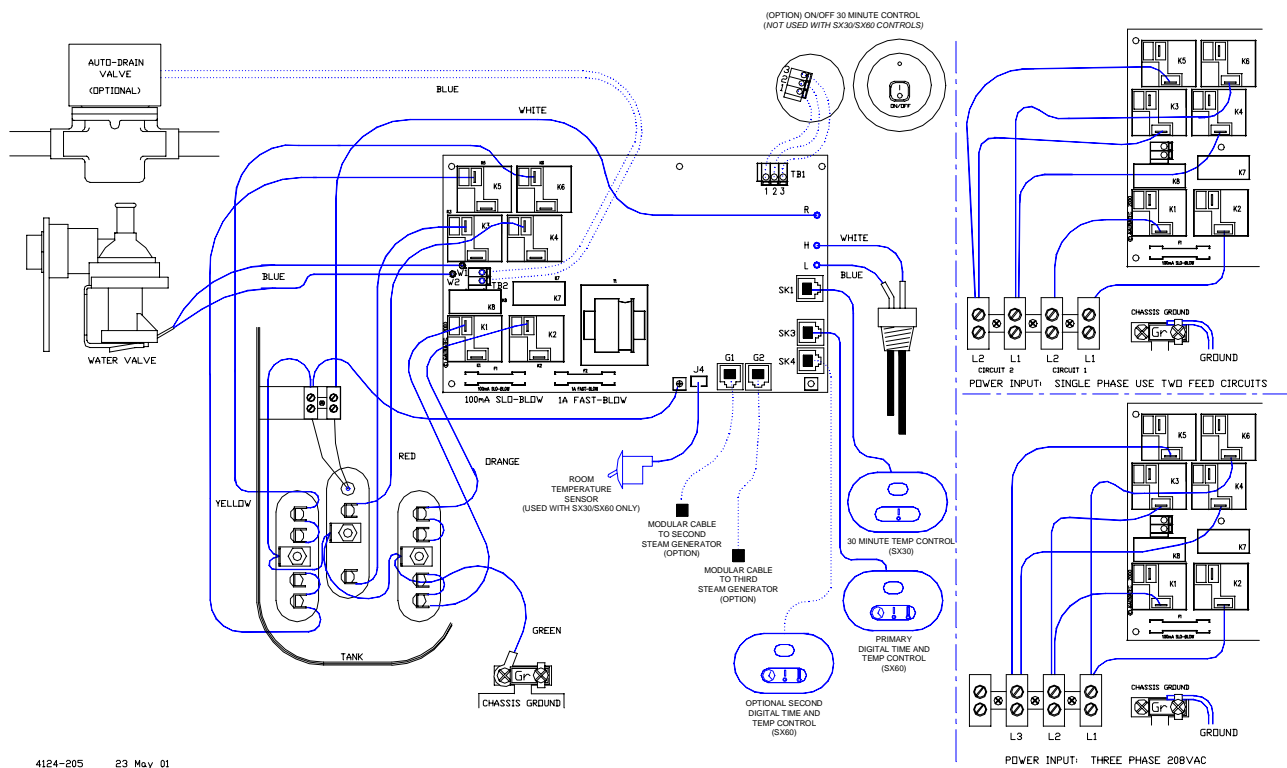

## **LIMITED WARRANTY STEAM GENERATOR PRODUCTS**

Saunatec Inc, warrants that its Steam Generators (warranted products) are free of manufacturing defects both as to workmanship and material for 5 years and it will replace or repair defective parts or equipment for the period of time and in accordance with the conditions set forth below. The terms of the warranty will be administered by Saunatec Inc.

1. **Applicability.** This warranty applies when the warranted product (a) is installed in accordance with installation instructions provided, (b) is properly and reasonably maintained, and (c) has not been subjected to damage, misuse, or abuse.

2. **Registration.** This warranty becomes valid only after the Limited Warranty Registration form, provided with this warranty, is completely filled in and signed by the original purchaser and mailed to SAUNATEC within sixty (60) days from the date of original installation. This warranty is non-transferable and shall extend only to the original purchaser.

3. **Duration of Warranty.** SAUNATEC or it's authorized representative will provide parts to replace those with manufacturing or workmanship defects for a period of five (5) years from the date of original installation, except when the warranted product is installed in commercial locations such as clubs, condominiums, apartments, spas or military facilities. In commercial locations, SAUNATEC or its authorized representative will provide parts to replace those with manufacturing or workmanship defects for a period of one (1) year from the date of original installation.

Additionally, for non-commercial locations in the United States SAUNATEC or its authorized representative will provide reasonable labor to replace defective parts for a period of two (2) years from the date of original installation and three (3) additional years if the product is returned to the factory.

4. **Warranty Work.** All warranty work must be (a) authorized by SAUNATEC before it is performed; and (b) performed only by authorized SAUNATEC representatives. This warranty shall not apply to any charges for parts or labor incurred before receiving approval by SAUNATEC.

5. **Return Goods Authorization Number.** A return goods authorization number assigned by an SAUNATEC representative must accompany all returned parts. Parts which are returned without a return authorization number may not be repaired or replaced.

-----

6. Procedure. Requests for repair or replacement, a return authorization number, or warranty information should be directed to SAUNATEC by calling toll-free 1-888-780-4427 or by writing to SAUNATEC, 575 E. Cokato Street, Cokato, MN 55321. Defective product or parts returned for repair or replacement must be shipped prepaid to SAUNATEC at the above address. Shipping costs for return of replacement product or parts to the purchaser will be at the expense of the purchaser.

7. Limitations, Exclusions, and Remedies. There are no warranties which extend beyond the descriptions on the face hereof. This limited warranty is in lieu of all warranties, expressed or implied, and of all other obligations or liabilities on the part of Saunatec. There shall be no implied warranty of merchantability. Saunatec neither assumes nor authorizes any person to assume for it any other obligation or liability in connection with the sale of its products.

Damages for breach of this warranty shall not exceed the lesser of the cost of repair or replacement. Repair or replacement shall be the exclusive remedy available to the purchaser.

Under no circumstances shall Saunatec be liable by virtue of this warranty or otherwise for any special, indirect, secondary, incidental, or consequential damage of any nature to any person or property arising directly or indirectly out of the use or inability to use a warranted product.

Some States do not allow limitations on how long an implied warranty lasts, or the exclusion or limitation of incidental or consequential damages, so the above limitations and exclusions may not apply to you.

8. Disputes. Any lawsuit alleging breach of this limited warranty shall be commenced within one year from the date of breach. In addition, any such lawsuit may be commenced only in Wright County, Minnesota.

This warranty gives you specific legal rights, and you may also have other rights which vary from State to State.



**LIMITED WARRANTY REGISTRATION FORM**  
**Please fill out and return within 60 days of installation to:**  
**SAUNATEC, 575 E. COKATO STREET, COKATO MN 55321**

The undersigned hereby acknowledges the receipt of the Limited Warranty and affirms that the date of installation was \_\_\_\_\_ 20\_\_\_\_, further that installation of the equipment has been completed according to the installation instructions furnished with the equipment and that I have read, understand and agree to the conditions and terms of the Limited Warranty in its entirety.

**Name of Purchaser** \_\_\_\_\_

**Address** \_\_\_\_\_

**City** \_\_\_\_\_ **St.** \_\_\_\_\_ **Zip** \_\_\_\_\_

**Phone** \_\_\_\_\_

**Purchaser's Signature** \_\_\_\_\_

**Model No.** \_\_\_\_\_ **Serial No.** \_\_\_\_\_